

Migrate an ExtraHop sensor

Published: 2025-04-10

When you are ready to upgrade your existing sensor, you can easily migrate to new hardware without losing business critical metrics and time-consuming system configurations.

The following customizations and resources are not saved when you create a backup or migrate to a new target.

- License information for the system. If you are restoring settings to a new target, you must manually license the new target.
- Precision packet captures. You can download saved packet captures manually by following the steps in [View and download packet captures](#).
- When restoring a virtual console that has a tunneled connection from a sensor, the tunnel must be reestablished after the restore is complete and any customizations on the console for that sensor must be manually recreated.
- User-uploaded TLS keys for traffic decryption.
- Secure keystore data, which contains passwords. If you are restoring a backup file to the same target that created the backup, and the keystore is intact, you do not need to re-enter credentials. However, if you are restoring a backup file to a new target or migrating to a new target, you must re-enter the following credentials:
 - Any SNMP community strings provided for SNMP polling of flow networks.
 - Any bind password provided to connect with LDAP for remote authentication purposes.
 - Any password provided to connect to an SMTP server where SMTP authentication is required.
 - Any password provided to connect to an external datastore.
 - Any password provided to access external resources through the configured global proxy.
 - Any password provided to access ExtraHop Cloud Services through the configured ExtraHop cloud proxy.
 - Any authentication credentials or keys provided to configure Open Data Stream targets.

Before you begin

 **Important:** If the source sensor has an external datastore and the datastore is configured on a SMB server requiring password authentication, contact ExtraHop Support to assist you with your migration.

- Source and target sensors must be running the same firmware version.
- Migrate only to the same type of sensors, such as RevealX Enterprise to RevealX Enterprise. If you need to migrate between sensor types (such as RevealX Enterprise to RevealX 360), contact your ExtraHop sales team for assistance.
- Migration is only supported between physical sensors. Virtual sensor migrations are not supported.
- Migration is only supported from an earlier series to a newer series (for example, you can only migrate an EDA 6200 to an EDA 6300, EDA 9300, or similar.) In addition, you can only migrate from a smaller sensor to a larger sensor.

RevealX Compatibility Matrix

Supported migration paths are listed in the following table.

Source	Target
EDA 1200	EDA 6200 EDA 8200 EDA 8320 EDA 9200 EDA 9300 EDA 10200 EDA 10300

Source	Target							
EDA 1200	YES	YES	YES	YES	YES	YES	YES	YES
EDA 6200	NO	YES*	YES	YES	YES	YES	YES	YES
EDA 8200	NO	NO	YES*	YES*	YES*	YES	YES	YES
EDA 8320	NO	NO	NO	YES	NO	YES	NO	YES
EDA 9200	NO	NO	NO	NO	YES*	YES	YES	YES
EDA 9300	NO	NO	NO	NO	NO	YES	NO	YES
EDA 10200	NO	NO	NO	NO	NO	NO	YES*	YES
EDA 10300	NO	NO	NO	NO	NO	NO	NO	YES

*Migration is supported only if the source and target sensor were manufactured in May 2019 or later. Contact ExtraHop Support to verify compatibility.

For information about the former Performance Edition, contact your ExtraHop representative for help.

Prepare the source and target sensors

1. Follow the instructions in the [deployment guide](#) for your sensor model to deploy the target sensor.
2. [Register](#) the target sensor.
3. Make sure that the target and the source sensor are running the exact same firmware version. You can download current and previous firmware from the [ExtraHop Customer Portal](#).
4. Choose one of the following networking methods to migrate to the target sensor.
 - (Recommended) To complete the migration in the fastest time possible, directly connect the sensors with 10G management interfaces.
 - [Create a bond interface \(optional\)](#) of available 1G management interfaces. With the appropriate network cables, directly connect the available port or ports on the source sensor to similar ports on the target sensor. The figure below shows an example configuration with bonded 1G interfaces.

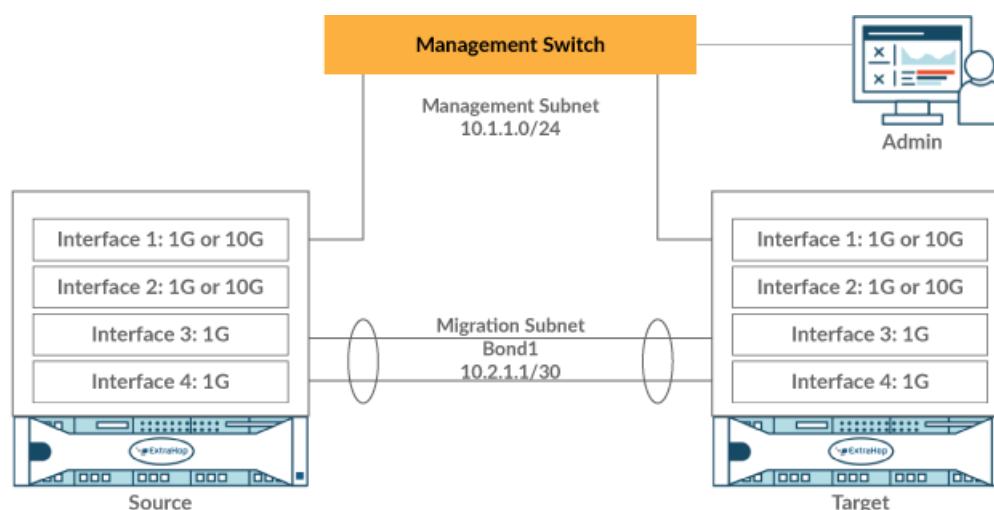

Important: Make sure that your IP address and subnet configuration on both sensors route management traffic to your management workstation and migration traffic to the direct link.

- Migrate the sensor over your existing network. The source and target sensors must be able to communicate with each other over your network. Note that migration might take significantly longer with this configuration.

Create a bond interface (optional)

Follow the instructions below to bond 1G interfaces. Creating a bond interface decreases the amount of time it takes to complete the migration over 1G interfaces.

Log in to the Administration settings on the ExtraHop system through `https://<extrahop-hostname-or-IP-address>/admin`.

1. In the Network Settings section on the source sensor, click **Connectivity**.
2. In the Bond Interface Settings section, click **Create Bond Interface**.
3. In the Members section, select the members of the bond interface depending on the sensor type. Do not include the current management interface, typically interface 1 or interface 3, in the bond interface.
4. From the **Take Settings From** drop-down menu, select one of the members of the new bond interface.
5. For Bond Type, select **Static**.
6. From the **Hash Policy** drop-down menu, select one of the following options:
 - **Layer 3+4** policy, which balances the distribution of traffic more evenly across interfaces; however, this policy is not fully compliant with 802.3ad standards.
 - **Layer 2+3** policy, which balances traffic less evenly and is compliant with 802.3ad standards.
7. Click **Create**.
8. On the Connectivity page, in the Bond Interfaces section, click **Bond Interface 1**.
9. From the **Interface Mode** drop-down menu, select **Management**.
10. Type the IPv4 Address, Netmask, and Gateway for your migration network.
11. Click **Save**.
12. Repeat this procedure on the target sensor.

Start the migration

Migration is recommended for upgrades where you want to retain the data and appliance configuration. Migration can take several hours to complete. During this time, neither the source nor the target sensor can collect data. The migration process cannot be paused or canceled.

1. Log in to the Administration settings on the source sensor.
2. In the Network Settings section, click **Connectivity**.
3. Write down the IP address of the management interface, DNS servers, and any static routes. You will configure these settings on the target after the migration completes.
4. In the Appliance Settings section, click **Appliance Migration**.
5. In the Target Appliance field, type the IP address of the interface you configured for migration on the target.
6. In the Setup User Password field, type the password of the setup user on the target.
The default password is the system serial number of the target sensor.
7. Click **Continue**.
8. On the Confirm Fingerprint page, make sure that the fingerprint that appears on this page exactly matches the fingerprint that appears on the Fingerprint page in the Administration settings on the target.

If the fingerprints do not match, make sure that you specified the correct hostname or IP address of the target that you entered in step 5.

9. Click **Start Migration**.
Wait for the migration success message to appear, which can take several hours. During the migration, the ExtraHop system on the target is inaccessible. If you inadvertently close the Appliance Migration Status page on the source, you can return to https://<source hostname>/admin/appliance_migration_status/ to continue monitoring the migration.

If the migration fails for any reason, restart the migration. If the migration continues to fail, contact ExtraHop Support for assistance.



Note: The target automatically reboots after the migration completes.

10. Click **Shut Down** to power off the source.



Important: To prevent sensor ID conflicts, do not power on the source sensor while it is connected to the same network where the target sensor is located unless you perform a factory reset with ExtraHop Rescue Media.

Configure the target sensor

If sensor networking is not configured through DHCP, make sure connectivity settings are updated, including any assigned IP addresses, DNS servers, and static routes. Connections to ExtraHop consoles, recordstores, and packetstores on the source sensor are automatically established on the target sensor when network settings are configured.

1. Log in to the Administration settings on the target sensor.
2. In the Network Settings section, click **Connectivity**.
3. In the Interfaces section, click the management interface (typically interface 1 or interface 3, depending on the sensor model).
4. In the IPv4 Address field, type the IP address of the source sensor.
5. Configure any static routes that were configured on the source sensor:
 - a) Click **Edit Routes**.
 - b) Add any required route information.

- c) Click **Save**.
6. Click **Save**.

Next steps

If you had to change any interface settings to perform the migration with bonded interfaces, make sure that the interface modes are configured as you expect them to be.

Restore any additional settings that **are not automatically restored**.